

ZAXIS-6 series

HITACHI

Reliable solutions

ZAXIS 26U



HYDRAULIC EXCAVATOR

Model code : ZX26U-6

Engine rated power : 15.6 kW (ISO14396)

Operating weight : Cab 2 720 kg

Canopy 2 570 kg

Bucket ISO heaped : 0.07 – 0.08 m³

ZX26U-6

The user-friendly excavator



6. Efficient performance



8. Exceptional comfort



10. Easy to maintain

No compromise

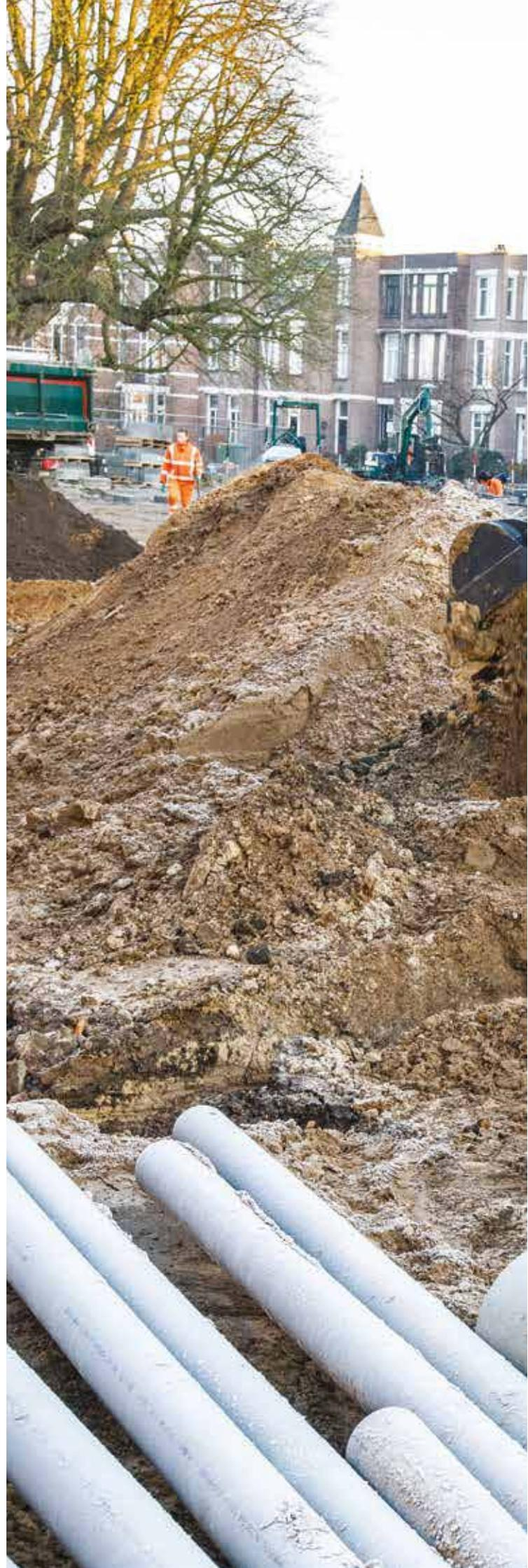



Perfect fit

Ideal for working in narrow or confined spaces, the ZX26U-6 is easy to transport from one job site to another. It is renowned for high levels of performance, exceptional comfort and easy maintenance, and is suitable for a variety of activities, including utilities, foundation work, landscaping, and indoor demolition and construction projects.



Enhanced visibility

Large front window and new optional rear-view mirror improve safety.



Short-tail swing radius

The short-tail swing radius is ideal for urban areas, where space is limited.



Comfortable cab

Wide adjustable suspension seat, folding foot pedals and adjustable armrest.



Energy efficient

LED lights on the cab and boom have a longer lifetime than halogen alternatives.



Added durability

Reinforced boom end bracket and boom cylinder guard enhance durability.



Easy maintenance

The radiator and oil cooler are conveniently positioned side by side.



Transport by trailer

Can be towed on a 3.5 tonne trailer with two buckets and a quick hitch.

Efficient performance

Fitted with a Stage V-compliant engine and the proven Hitachi hydraulic system, the ZX26U-6 will work productively and efficiently. Lightweight and compact, it is easy to transport and can fit in confined spaces on busy job sites.

High productivity

The ZX26U-6 delivers high levels of productivity with reduced running costs.

Outstanding versatility

The ZX26U-6 is easy to transport between different job sites. It can be towed on a 3.5 tonne trailer with two buckets and a quick hitch (with a category B+E driving licence).

Built to last

Durable features of the ZX26U-6 – such as the boom cylinder guard, hose protection and reinforced boom end bracket – ensure a reliable performance, helping you to get the job done on time and on budget.



Quick cycle time and efficient hydraulics ensure high productivity.



The front of the machine is fitted with a boom cylinder guard for added durability.



Short-tail swing radius is ideal for working in narrow spaces.



Controls are within easy reach.



Large window and door provide excellent visibility.



Exceptional comfort

The cab of the ZX26U-6 has been designed to provide a pleasant environment for operators and ensure they feel less tired at the end of the working day. It incorporates user-friendly controls, a large front window and door that enhance visibility, and an entrance step for easy access.

Spacious cab

Fitted with a wide and adjustable sliding suspension seat, folding foot pedals and adjustable arm rest, the ZX26U-6 provides a high level of comfort for operators.

Easy operation

User-friendly controls are in easy reach of the operator and the hydraulic pilot control levers ensure a smooth operation. Low noise levels allow operators to work more comfortably.

Enhanced design

The ZX26U-6 is equipped with new LED lights on the cab and boom. These have a longer lifetime than halogen alternatives for efficient energy use.



The wide adjustable suspension seat is comfortable for operators.

Easy to maintain

Convenient maintenance features are integral to the design of the user-friendly ZX26U-6. They not only enable quick and easy servicing and cleaning, but also ensure a high level of availability and optimum performance.

Convenient access

The engine and radiator covers have been designed to allow easy access. Sufficient space around the fuel tank opening of the new mini excavators makes it easy to refuel.

Quick cleaning

The dozer blade openings minimise the build-up of dirt and make it easier to remove.

Safety first

The battery disconnect switch is now available as standard for safer and easier maintenance.



The battery disconnect switch allows maintenance to be carried out safely.



Easy to open covers provide quick access.



Sufficient space around the fuel tank opening for easy refuelling.

SPECIFICATIONS

ENGINE

Model	3TNV76
Type	Water-cooled, 4-cycle, swirl combustion chamber injection type diesel engine
No. of cylinders	3
Rated power	
ISO 14396	15.6 kW at 2 500 min ⁻¹
ISO 9249, net	14.5 kW at 2 500 min ⁻¹
SAE J1349, net	14.5 kW (19.4 HP) at 2 500 min ⁻¹ (rpm)
Maximum torque	64.1 Nm at 1 800 min ⁻¹
Piston displacement	1.115 L
Bore and stroke	76 mm x 82 mm
Battery	1 x 12 V / 36 Ah

HYDRAULIC SYSTEM

Hydraulic Pumps

Main pumps	2 variable displacement axial piston pumps 1 gear pump
Maximum oil flow	2 x 30.0 L/min 1 x 16.3 L/min
Pilot pump	1 gear pump
Maximum oil flow	6.8 L/min

Hydraulic Motors

Travel	2 variable displacement axial piston motors
Swing	1 gear pump

Relief Valve Settings

Implement circuit	24.5 MPa (250 kgf/cm ²)
Swing circuit	18.6 MPa (190 kgf/cm ²)
Travel circuit	24.5 MPa (250 kgf/cm ²)
Pilot circuit	3.9 MPa (40 kgf/cm ²)

Hydraulic Cylinders

	Quantity	Bore	Rod diameter	Stroke
Boom (Cab)	1	75 mm	45 mm	553 mm
Boom (4-Pillar canopy)	1	75 mm	45 mm	567 mm
Arm	1	65 mm	40 mm	549 mm
Bucket	1	55 mm	35 mm	437 mm
Blade	1	75 mm	45 mm	144 mm
Boom swing	1	75 mm	40 mm	415 mm

UPPERSTRUCTURE

Swing Device

The axial piston motor with planetary reduction gear is bathed in oil and the swing circle is single-row. The swing parking brake is of the spring-set / hydraulic-released disc type.

Swing speed	9.1 min ⁻¹ (rpm)
Swing torque	3.6 kNm (367 kgfm)

Operator's Cab

An independent spacious cab, 1 050 mm wide by 1 610 mm high, conforming to ISO* Standards. Reinforced glass windows on 4 sides for visibility. Front windows (upper and lower) can be opened.

* International Organization for Standardization

UNDERCARRIAGE

Tracks

Tractor-type undercarriage. Welded track frame using selected materials. Side frame welded to track frame.

Numbers of Rollers on Each Side

Upper rollers	1
Lower rollers	4

Travel Device

Each track driven by a 2-speed axial piston motor. Parking brake is of the spring-set/hydraulic-released disc type. Automatic transmission system: High-Low.

Travel speeds	High : 0 to 4.5 km/h Low : 0 to 2.9 km/h
---------------------	---

Maximum traction force ... 20.1 kN (2 050 kgf)

Gradeability

47% (25 degree) continuous

SOUND LEVEL

Sound level Canopy according to ISO 6396	Lpa 78 dB (A)
Sound level Cab according to ISO 6396	Lpa 78 dB (A)
External sound level according to ISO 6395 and EU Directive 2000/14/EC	LwA 93 dB (A)

SERVICE REFILL CAPACITIES

Fuel tank	31.3 L
Engine coolant	3.1 L
Engine oil	3.7 L
Travel device (each side)	0.6 L
Hydraulic system	39.0 L
Hydraulic oil tank	24.1 L

WEIGHTS AND GROUND PRESSURE

Operating Weight and Ground Pressure

CAB				
Shoe type	Shoe width	Arm length	kg	kPa (kgf/cm ²)
Rubber shoe	300 mm	1.30 m	2 720*	25.9 (0.26)

Including 2.10 m boom and 0.080 m³ bucket (ISO heaped).

* Operating weight with fully serviced, +80 kg operator ISO 6016.

4-PILLAR CANOPY

Shoe type	Shoe width	Arm length	kg	kPa (kgf/cm ²)
Rubber shoe	300 mm	1.30 m	2 570*	25.9 (0.26)

Including 2.10 m boom and 0.080 m³ bucket (ISO heaped).

* Operating weight with fully serviced, +80 kg operator ISO 6016.

BUCKET AND ARM DIGGING FORCE

Arm length	1.30 m
Bucket digging force ISO	22.3 kN (2 270 kgf)
Bucket digging force SAE : PCSA	18.0 kN (1 830 kgf)
Arm crowd force ISO	14.5 kN (1 480 kgf)
Arm crowd force SAE : PCSA	13.6 kN (1 390 kgf)

BACKHOE ATTACHMENTS

Boom and arms are of welded, box-section design. A 2.10 m boom and 1.30 m arm are available.

Buckets

Capacity ISO heaped	Width		No. of teeth	Weight	Recommendation
	Without side cutters	With side cutters			Arm 1.30 m
0.070 m ³	400 mm	450 mm	3	61.0 kg	○
0.080 m ³	450 mm	500 mm	3	64.0 kg	○

○ Suitable for materials with density of 2 000 kg/m³ or less

SPECIFICATIONS

WORKING RANGES

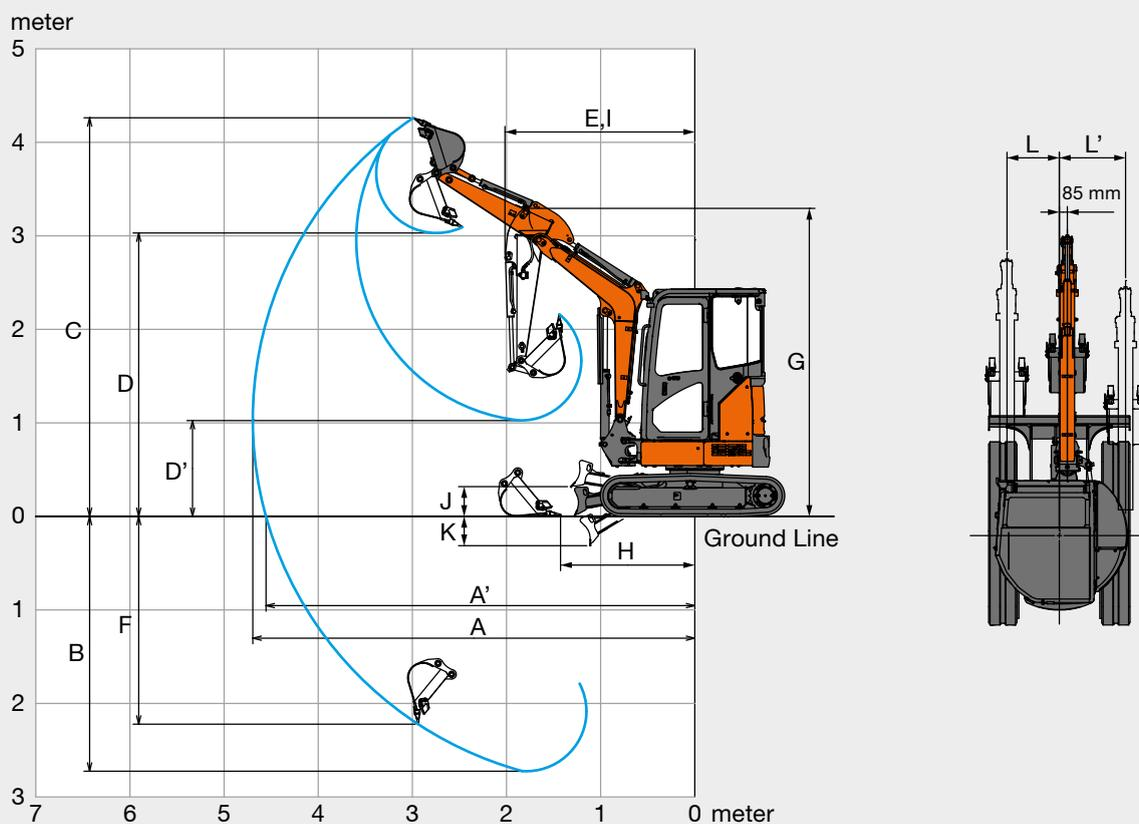

This illustration shows with 1.30 m arm, 0.080 m³ bucket and 300 mm rubber shoes.

Unit: mm

	ZAXIS 26U	
	Cab	1.30 m arm
		4-Pillar Canopy
A Max. digging reach		4 710
A' Max. digging reach (on ground)		4 570
B Max. digging depth		2 730
C Max. cutting height	4 260	4 450
D Max. dumping height	3 030	3 200
D' Min. dumping height	1 030	1 120
E Min. swing radius	2 020	1 940
F Max. vertical wall digging depth		2 220
G Front height at Min. swing radius	3 290	3 380
H Min. level crowding distance		1 430
I Working radius at Min. swing radius (Max. boom-swing angle)	1 320	1 270
J Blade bottom highest position above ground		320
K Blade bottom lowest position above ground		315
L/L' Offset distance		555 / 700
Max. boom-swing angle (deg.)		70 / 60

DIMENSIONS

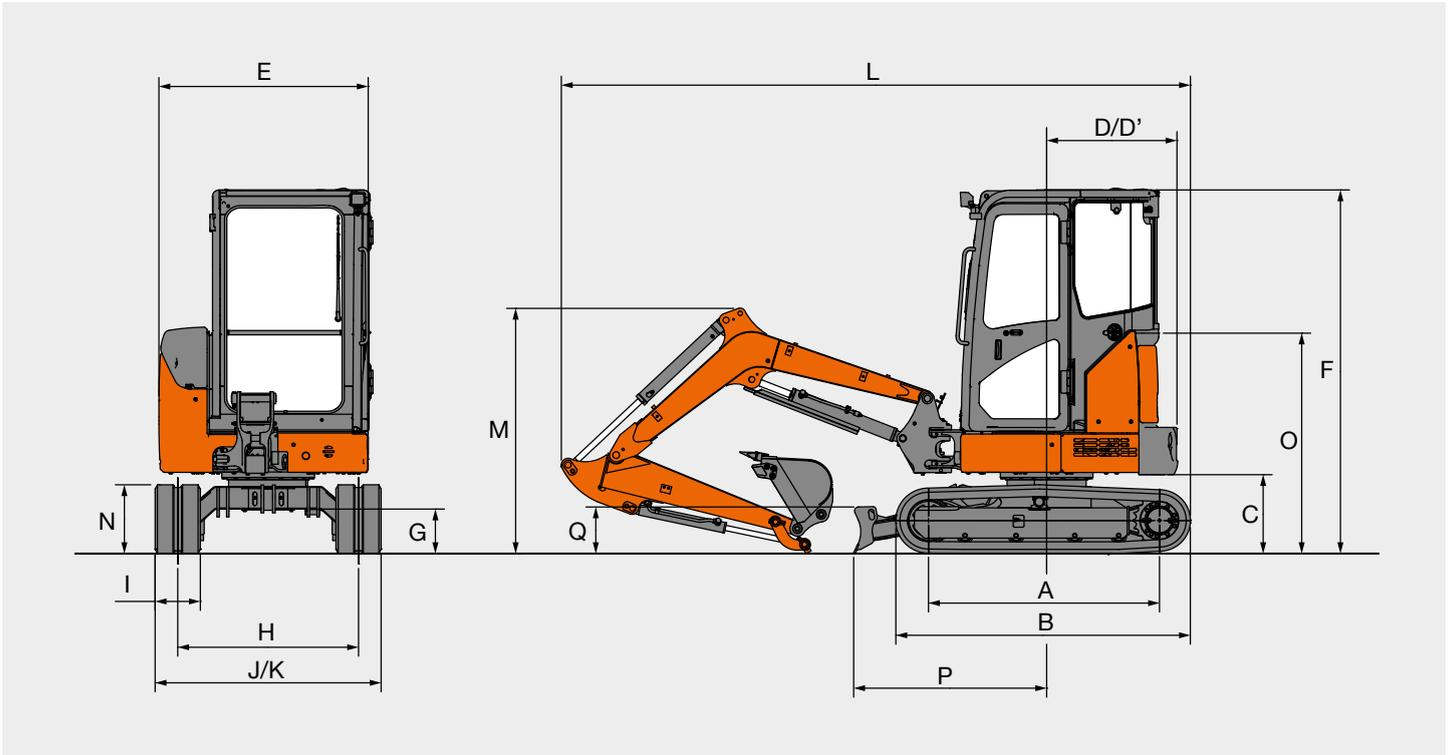

This illustration shows with 1.30 m arm, 0.080 m³ bucket and 300 mm rubber shoes.

Unit: mm

	ZAXIS 26U	
	Cab	4-Pillar Canopy
A Distance between tumblers	1 530	
B Undercarriage length	1 960	
C Counterweight clearance	540	
D Rear-end swing radius	870	
D' Rear-end length	870	
E Overall width of upperstructure	1 420	1 390
F Overall height of cab	2 430	
G Min. ground clearance	300	
H Track gauge	1 200	
I Track shoe width	300	
J Undercarriage (Blade) width	1 500	
K Overall width	1 500	
L Overall length	4 100	
M Overall height of boom	1 640	
N Track height	465	
O Engine cover-height	1 470	1 490
P Horizontal distance to blade	1 280	
Q Blade height	320	

MACHINE CAPACITIES

- Notes: 1. Ratings are based on ISO 10567.
 2. Lifting capacity does not exceed 75% of tipping load with the machine on firm, level ground or 87% full hydraulic capacity.
 3. The load point is the center-line of the bucket pivot mounting pin on the arm.
 4. *Indicates load limited by hydraulic capacity.
 5. 0 m = Ground.

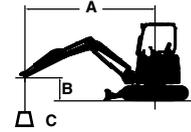

A: Load radius
 B: Load point height
 C: Lifting capacity

To determine lifting capacities, apply "Rating over-side or 360 degrees" machine capacities from table with "Blade above Ground" and deduct weight of installed attachment and quick hitch.

ZAXIS 26U CAB Version, Blade above Ground

Rating over-front Rating over-side or 360 degrees Unit : 1 000 kg

Conditions	Load point height m	Load radius								At max. reach		
		1.0 m		2.0 m		3.0 m		4.0 m				meter
Boom 2.10 m Arm 1.30 m Counterweight 150 kg Rubber shoe 300 mm	2.0					0.56	0.41			0.35	0.26	3.93
	1.0					0.52	0.38	0.33	0.24	0.33	0.24	4.07
	0 (Ground)			0.93	0.64	0.50	0.36			0.34	0.25	3.90
	-1.0	*1.68	*1.68	0.94	0.65	0.50	0.36			0.43	0.31	3.35
	-2.0			*0.88	0.69					*0.88	0.69	2.01

ZAXIS 26U CAB Version, Blade on Ground

Rating over-front Rating over-side or 360 degrees Unit : 1 000 kg

Conditions	Load point height m	Load radius								At max. reach		
		1.0 m		2.0 m		3.0 m		4.0 m				meter
Boom 2.10 m Arm 1.30 m Counterweight 150 kg Rubber shoe 300 mm	2.0					*0.75	0.41			*0.59	0.26	3.93
	1.0					*1.01	0.38	0.76	0.24	*0.63	0.24	4.07
	0 (Ground)			*1.81	0.64	*1.18	0.36			*0.77	0.25	3.90
	-1.0	*1.68	*1.68	*1.94	0.65	*1.09	0.36			*0.89	0.31	3.35
	-2.0			*0.88	0.69					*0.88	0.69	2.01

ZAXIS 26U 4-Pillar Canopy Version, Blade above Ground

Rating over-front Rating over-side or 360 degrees Unit : 1 000 kg

Conditions	Load point height m	Load radius								At max. reach		
		1.0 m		2.0 m		3.0 m		4.0 m				meter
Boom 2.10 m Arm 1.30 m Counterweight 240 kg Rubber shoe 300 mm	2.0					0.54	0.40			0.35	0.25	3.93
	1.0					0.51	0.37	0.33	0.24	0.32	0.23	4.07
	0 (Ground)			0.91	0.62	0.48	0.35			0.33	0.24	3.90
	-1.0	*1.68	*1.68	0.92	0.63	0.48	0.35			0.41	0.30	3.35
	-2.0			*0.88	0.68					*0.88	0.67	2.01

ZAXIS 26U 4-Pillar Canopy Version, Blade on Ground

Rating over-front Rating over-side or 360 degrees Unit : 1 000 kg

Conditions	Load point height m	Load radius								At max. reach		
		1.0 m		2.0 m		3.0 m		4.0 m				meter
Boom 2.10 m Arm 1.30 m Counterweight 240 kg Rubber shoe 300 mm	2.0					*0.75	0.40			*0.59	0.25	3.93
	1.0					*1.01	0.37	0.74	0.24	*0.63	0.23	4.07
	0 (Ground)			*1.81	0.62	*1.18	0.35			*0.77	0.24	3.90
	-1.0	*1.68	*1.68	*1.94	0.63	*1.09	0.35			*0.89	0.30	3.35
	-2.0			*0.88	0.68					*0.88	0.67	2.01

EQUIPMENT

● : Standard equipment

○ : Optional equipment

ENGINE

Air cleaner double filters	○
Alternator 12V - 40 A	●
Cartridge-type engine oil filter	●
Fuel main filter	●
Radiator reserve tank	●
Water-separator for engine fuel	●

HYDRAULIC SYSTEM

Full-flow filter	●
Hydraulic pilot type control levers	●
Pilot control shut-off lever with neutral engine start system	●
Pilot filter	●
Suction filter	●
Swing parking brake	●
Travel parking brake	●
Two-speed travel system	●
Valve for extra piping	●

CAB

AM/FM radio	●
Anti-slip plate	●
Arm rests	●
Defroster	●
Drink holder	●
Electric horn	●
Floor mat	●
Heater	●
Power outlet 12V (inside)	○
Power outlet 12V (outside)	○
ROPS/OPG cab	●
Seat belt	●
Sun visor (front window (light type))	○
Suspension seat	●
Window washer	●
Wiper	●

4-PILLAR CANOPY

Anti-slip plate	●
Arm rests	●
Drink holder	●
Electric horn	●
Floor mat	●
Power outlet 12V (inside)	○
ROPS/OPG canopy	●
Seat belt	●
Suspension seat	●

LIGHTS

2 working light	●
2 working LED light	○

UPPERSTRUCTURE

Auxiliary function lever (AFL)	○
Auxiliary overload relief valve	○
Batteries 1 x 36 Ah	●
Battery disconnect switch	●
Counterweight (cab) 150 kg	●
Counterweight (4-pillar canopy) 240 kg	●
Pilot accumulator	○

UNDERCARRIAGE

Rubber shoe 300 mm	○
--------------------	---

FRONT ATTACHMENTS

Arm 1.30 m	●
Boom 2.10 m	●
Extra piping	●
HN bushing	●

MISCELLANEOUS

Theft deterrent system*	○
-------------------------	---

Standard and optional equipment may vary by country, so please consult your Hitachi dealer for details.

* Hitachi Construction Machinery cannot be held liable for theft, any system will just minimize the risk of theft.

Prior to operating this machine, including satellite communication system, in a country other than a country of its intended use, it may be necessary to make modifications to it so that it complies with the local regulatory standards (including safety standards) and legal requirements of that particular country. Please do not export or operate this machine outside the country of its intended use until such compliance has been confirmed. Please contact your Hitachi dealer in case of questions about compliance.

These specifications are subject to change without notice. Illustrations and photos show the standard models, and may or may not include optional equipment, accessories, and all standard equipment with some differences in color and features. Before use, read and understand the Operator's Manual for proper operation.